



PC - Powerful Compact[®] Residential Electric

Features:



Bradford White is ISO registered to the 9001- standard.

- **Compact design**—can be mounted almost anywhere - under a sink, inside cabinets or hung on a wall (12 ¼"(311mm)H x 9 ⅞" (251mm) dia.)
- **Non-CFC insulation**—precast surrounds tank.
- **Fully automatic control**—fast acting surface-mount thermostat for automatic temperature control. Factory installed (sensitive) manual reset energy cut-off for safety to prevent overheating.
- **Direct heat transfer with immersed element**—transfers heat directly and efficiently to the water. Screw-in style.
- **Deep drawn steel tank**—with Bradford White Vitraglas[®] lining.
- **Protective magnesium anode rod**—provides added protection against corrosion for long, trouble free service.
- **Steel Jacket**—with special coating that inhibits rust and corrosion.
- **Ideal application**—anywhere remote hot water is needed.
- **T&P relief valve opening**—special tapping on top of tank.
- **Six or ten year limited warranty on steel tank.** (Except where noted).
- **Six year limited warranty on parts.**

Optional Features:

- **Wall mounting bracket**
- **Aluminum anode rod**
- **Incoloy elements**
- **North Carolina compliant**

MANUFACTURED UNDER ONE OR MORE OF THE FOLLOWING U.S. PATENTS:
5,954,492; 5,761,379; 5,943,984; 5,081,696; 5,988,117; 6,142,216; 5,199,385;
6,684,821; 5,574,822; 5,372,185; 5,485,879; 5,277,171; (B1)5,341,770; 5,660,165;
5,596,952; 5,682,666; 4,904,428; 5,023,031; 5,000,893; 4,669,448; 4,829,983;
4,808,356; 5,115,767; 5,092,519; 5,052,346; 4,416,222; 4,628,184; 4,861,968;
4,672,919; Re. 34,534. OTHER U.S. AND FOREIGN PATENT APPLICATIONS
PENDING. CURRENT CANADIAN PATENTS: 1,272,914; 1,280,043; 1,289,832;
2,045,862; 2,112,515; 2,108,186; 2,107,012.



Residential Electric Water Heater — Powerful Compact®

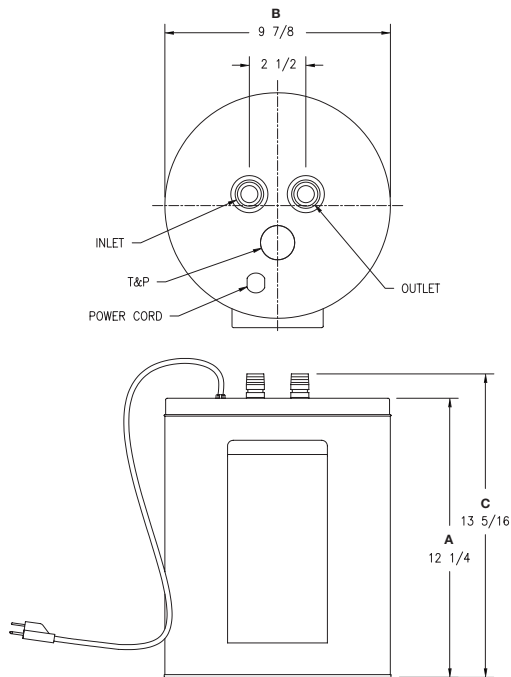

Ease of installation makes this Powerful Compact one of the most practical heaters in the Bradford White line. Perfect for “wash station” applications – for factories, stores, and offices. In fact, anywhere a small quantity of hot water is needed in remote locations.

Because it uses ordinary 120 Volt current and because its size is so small, it can be mounted almost anywhere near the outlet fixture, thus eliminating costly heat loss in long pipe runs.

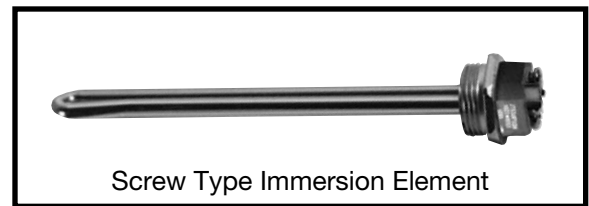

Screw Type Immersion Element

Powerful Compact Electric Model

C.E.C. Listed

Model	Gal. Cap.	Liter Cap	Style	GPH Recovery 50°C./90°F. Rise	LPH Recovery 50°C./90°F. Rise	A		B		C		Approx. Shpg. Wt.	
						in	mm	in	mm	in	mm	lbs.	kg.
M1-2U6SS	2	7.6	Utility	7	26	12¼	311	9¾	251	13⅝	338	12	5

Note: The Powerful Compact Heater will be wired for 120 volt service, with 1500 watt element only. Equipped with precast non-CFC insulation, includes 4 ft. (1.2 meters) cord with 3 prong grounded plug. 20 AMP circuit required.

General

All models UL and C-UL listed. All water connections, ¼" (19mm) NPT. T&P connection, ¾" (19mm) NPT female.

All models certified at 300 psi (2068 kPa) test pressure, 150 psi (1034 kPa) working pressure.

Dimensions and specifications subject to change without notice in accordance with our policy of continuous product improvement.

* Wall Mounting Bracket can be purchased separately through Bradford White Parts Department. (Part # 265-45018-00)

6-Year Limited Warranty on Component Parts

BRADFORD WHITE CORPORATION has a 6-year warranty on replaceable parts—thermostat, drain plug, dip tube and element. These quality components are manufactured for us by industry leaders and will be replaced in the event of failure during the parts warranty period (exclusive of shipping and re-installation cost.)§

§ Some states do not allow limitations on warranties. See complete copy of the warranty included with the product. Indicated warranties apply to USA, Canada and Puerto Rico installations.

Vitraglas® and Powerful Compact® are registered trademark's of Bradford White® Corporation.

©2004, Bradford White Corporation. All rights reserved.

6 or 10-Year Limited Tank Warranty

BRADFORD WHITE CORPORATION LIMITED WARRANTY: Protects your investment in a quality water heater. If the tank leaks for reasons of faulty materials, workmanship, or corrosion within the warranty period, the heater will be replaced with a comparable heater of our manufacture (exclusive of shipping and re-installation cost.)§



For U.S. and Canada field service, contact your professional installer or local Bradford White sales representative.

Sales/800-523-2931
Fax/215-641-1670

Technical Support/800-334-3393
Fax/269-795-1089

Warranty/800-531-2111
Fax/269-795-1089

International:
Telephone/215-641-9400
Telefax/215-641-9750

Fax on Demand:
888-538-7833

www.bradfordwhite.com



Sales/Technical Support
866-690-0961
905-238-0100

Fax/905-238-0105

www.bradfordwhitecanada.com

PRODUCTS ONLY FOR PROFESSIONALS